



FORTIS

AREAS OF APPLICATION

Shops • Cafes • Restaurants • Parking Lots • Offices • Training Halls • Hospitals
• Hangars • Warehouses • Factories • Facilities • Sports Facilities
Designed for use in environments that demand long-lasting and high lumen lighting.



FORTIS

TRI-PROOF LUMINAIRE



PRODUCT SPECIFICATIONS

- Body** : Alu Body / PC Cover
- Optic** : Opal PC Diffuser
- Driver** : Osram-Tridonic-Philips-3N
- Led Chip** : Samsung, Osram, Seoul
- Input Voltage** : 220-240V/AC 50-60Hz
- Temperature Range** : -10°C~+40°C
- CRI** : CRI > 80
- IP Class** : IP65
- Options** : Application Options : Surface / Pendant
Color temperature : 3000K/4000K/6500K
Emergency Kit- DALI

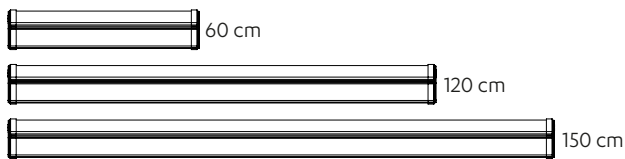

PHOTOMETRIC DISTRIBUTION

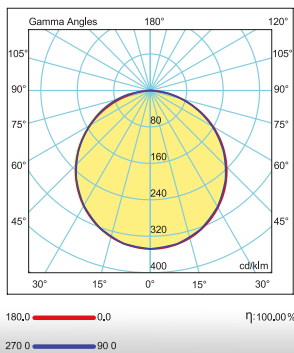

TECHNICAL DRAWING

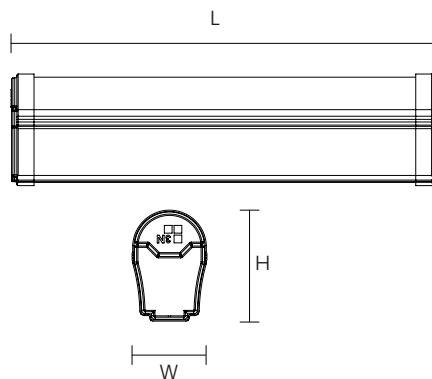

ACCESSORIES

Surface Mounted Hanger



R070.10.00002

OPTIONAL ACCESSORIES

Pendant Hanger



SP060.10.00006

1,2M. Pendant Wire



C030.98.12001

PRODUCT SPECIFICATIONS

| Item Code | Power (W) | Luminaire Lumen (lm) | Color Temperature (K) | Efficiency (lm/W) | Dimensions (LxWxH) | Qty/Carton | Carton Size (LxWxH) | G.W/Carton |
|-----------|-----------|----------------------|-----------------------|-------------------|--------------------|------------|---------------------|------------|
| LET30.020 | 20W | 2.200 | 3000/4000/6500 | 110lm/W | 600x55x85mm | 18 | 1260x200x270mm | 13.96 kg |
| LET30.036 | 36W | 3.960 | 3000/4000/6500 | 110lm/W | 1200x55x85mm | 9 | 1260x200x270mm | 13.96 kg |
| LET30.045 | 45W | 4.950 | 3000/4000/6500 | 110lm/W | 1500x55x85mm | 9 | 1600x100x100mm | 15.96 kg |
| LET30.055 | 60W | 7.800 | 3000/4000/6500 | 130lm/W | 1500x55x85mm | 9 | 1600x100x100mm | 15.96 kg |

*3N Company has the right to make any changes it deems necessary without prior notice.
*Technical data has a tolerance of ± 10%.