



FORTIS

AREAS OF APPLICATION

Shops • Cafes • Restaurants • Parking Lots • Offices • Training Halls • Hospitals
• Hangars • Warehouses • Factories • Facilities • Sports Facilities
Designed for use in environments that demand long-lasting and high lumen lighting.



FORTIS SMART

TRI-PROOF LUMINAIRE



PRODUCT SPECIFICATIONS

- Body** : Alu Body / PC Cover
- Optic** : Opal PC Diffuser
- Driver** : Osram-Tridonic-Philips-3N
- Led Chip** : Samsung, Osram, Seoul
- Input Voltage** : 220-240V/AC 50-60Hz
- Temperature Range** : -10°C~+40°C
- CRI** : CRI > 80
- IP Class** : IP65
- Options** : Application Options : Surface / Pendant
Color temperature : 3000K/4000K/6500K
Emergency Kit- DALI

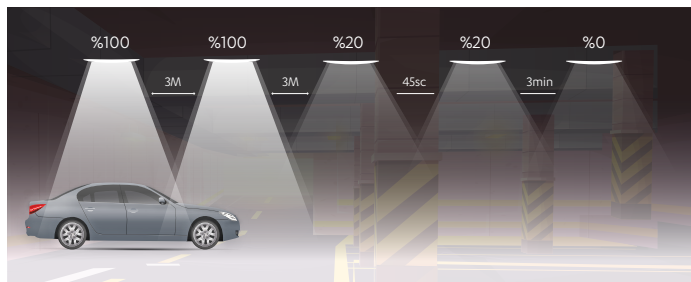
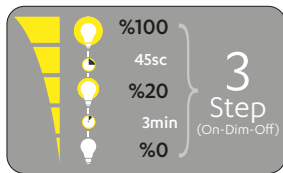
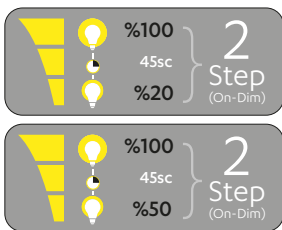

PHOTOMETRIC DISTRIBUTION

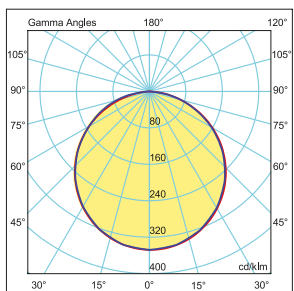

TECHNICAL DRAWING

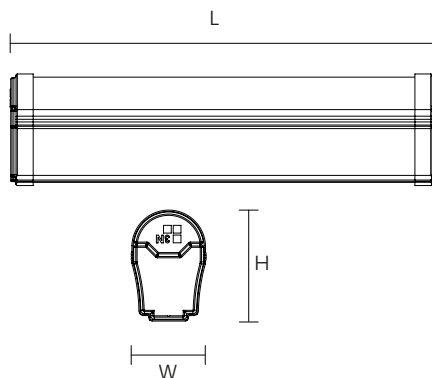

ACCESSORIES



OPTIONAL ACCESSORIES



PRODUCT SPECIFICATIONS

Item Code	Power (W)	Luminaire Lumen (lm)	Color Temperature (K)	Efficiency (lm/W)	Dimensions (LxWxH)	Qty/Carton	Carton Size (LxWxH)	G.W/Carton
LET30.036	24W	3.000	3000/4000/6500	125lm/W	1200x55x85mm	9	1310x310x320mm	13.96 kg
LET30.036	36W	4.500	3000/4000/6500	125lm/W	1200x55x85mm	9	1310x310x320mm	13.96 kg

*3N Company has the right to make any changes it deems necessary without prior notice.
*Technical data has a tolerance of ± 10%.