



LED BULBS

AREAS OF APPLICATION

Residences • Cafes • Restaurants • Markets • Stores



LED GU10 BULB WITH LENS



PRODUCT SPECIFICATIONS

Power	: 5W
Energy Class	: F
Base Type	: E14
Input Voltage	: 170-240V - 50/60Hz
Beam angle	: 200
Luminous Flux	: 450 lm
Color Temperature (CCT)	: 3000K/4000K/6500K
Lifespan	: 20.000 Hour
Working Temperature	: -20°C~+40°C

PHOTOMETRIC DISTRIBUTION

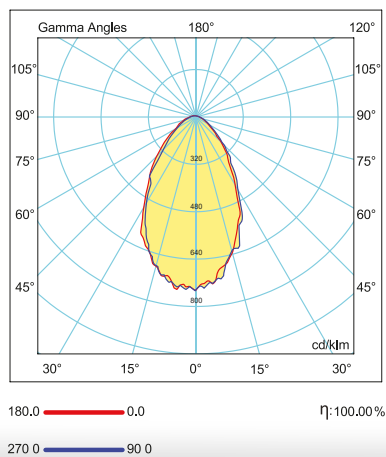

TECHNICAL DRAWING

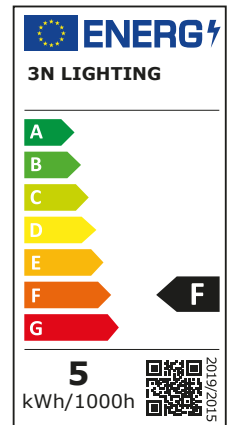
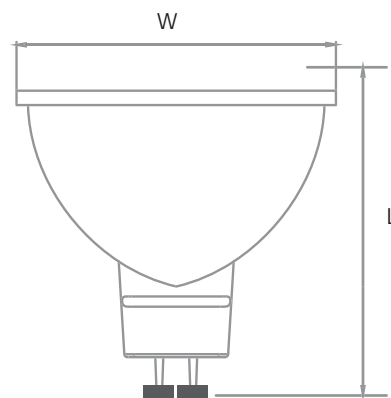

PRODUCT SPECIFICATIONS

Item Code	Power (W)	Luminaire Lumen (lm)	Color Temperature (K)	Efficiency (lm/W)	Dimensions (LxWxH)	Qty/Carton	Carton Size (LxWxH)	G.W/Carton
LLB10.005	5W	450	3000/4000/6500	95lm/W	55x45mm	100	560x265x130mm	-

*3N Company has the right to make any changes it deems necessary without prior notice.
*Technical data has a tolerance of $\pm 10\%$.